

UHF-RW-MP-232-V1

Embedded UHF Reader/writer with RS232 interface

Features

- Operation mode : read/write UHF Tag ID & memory
- support multi-tag reading
- Antenna : build-in circular polarization antenna
- Standard Frequency : 902-928Mhz (can be defined by user)
- optional interface : RS232 / wiegand
- Transmission Power : < 30dbm (software programmable)
- support : ISO18000-6C EPC G2 or ISO18000-6B UHF tag
- power supply : +9V DC ,3A
- free software pack (Delphi demo program with source code , protocol ..)
- software compatobe with UHF-RW-MP-232-D2
- **7 dbi antenna built-in version**
 - ✧ reading range : ~3-5 meters (depend on site environment)
 - ✧ Peak power Transmitter : < 1 watt
 - ✧ Dimension : (220x220x30)mm
 - ✧ weight : 2kg
- **12 dbi antenna built-in version**
 - ✧ reading range : ~5-8 meters (depend on site environment)
 - ✧ Peak power Transmitter : < 2 watt
 - ✧ Dimension : (440x440x50)mm
 - ✧ weight : 5kg

Ordering part No

UHF-RW-MP-232-V1-7dbi	Embedded UHF G2 & ISO18000-6C reader/writer with RS232 interface / 7dbi antenna / US frequency : 902-928 Mhz
UHF-RW-MP-232-V1-12dbi	Embedded UHF G2 & ISO18000-6C reader/writer with RS232 interface / 12 dbi antenna / US frequency : 902-928 Mhz

Wire assignment

Item	Comment
Red	+9V
Black	GND
Yellow	Wiegand DATA0
Blue	Wiegand DATA1
Purple	RS485 R+ (optional)
Orange	RS485 R- (optional)
Brown	GND
White	RS232 RXD
Green	RS232 TXD
Grey	Trigger input (TTL level)



Remarks : RS485 interface is not available for RS232 version.

Demo Program Instruction

Connected reader with PC through RS232 com port.

Run the demo program from path: \\demo program\RRU1861demomain.exe

Click on "Reader Parameter" from menu bar

Select correct COM port or "AUTO" and click on "Open COM Port"

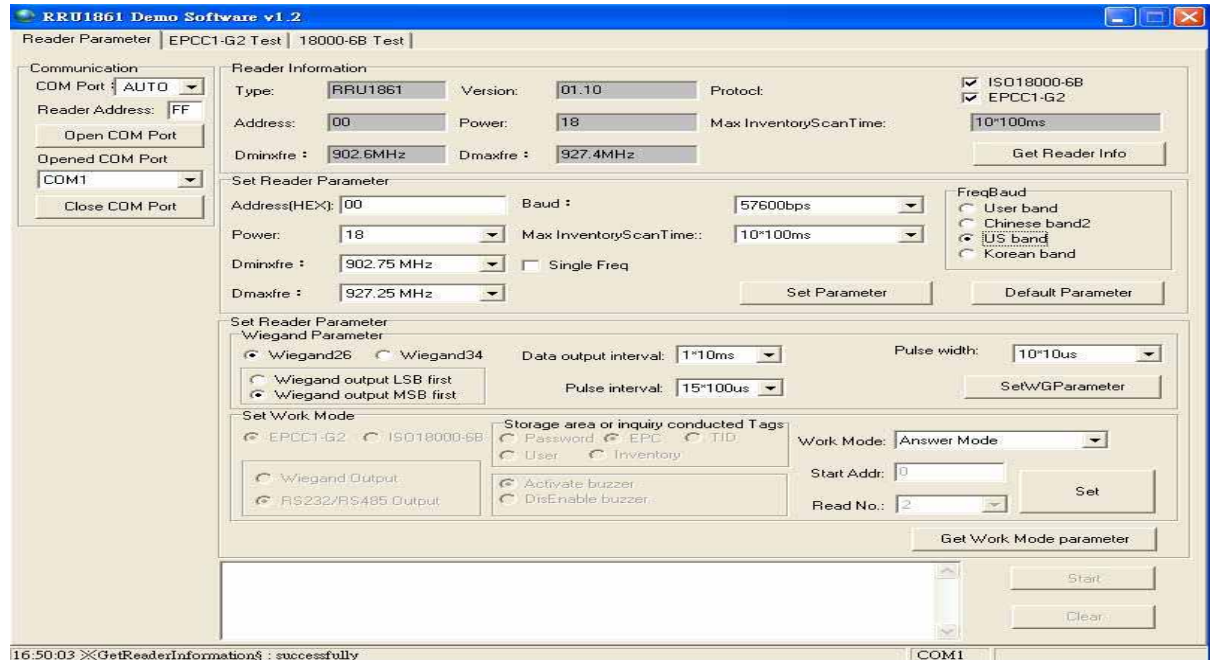

Reader Information

Click on "Get Reader Info" to get Reader information

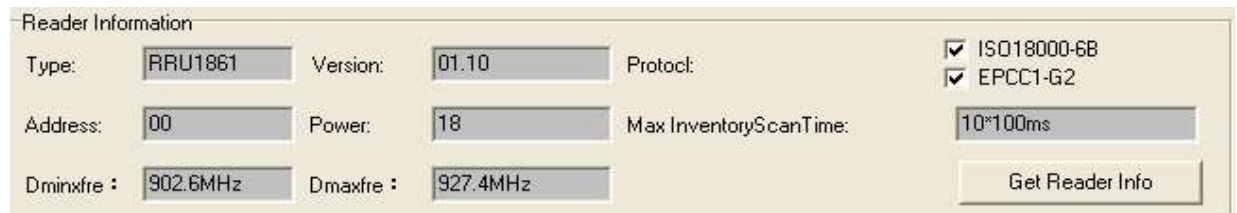

Set Reader Parameter

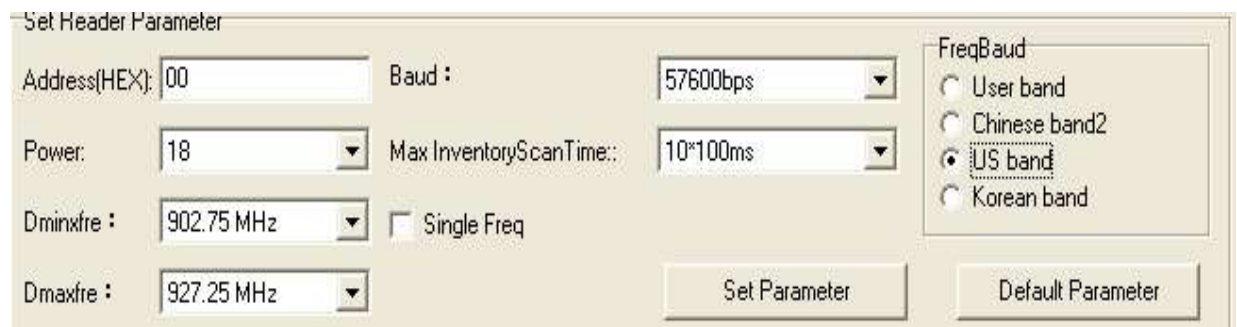

Address : Reader address
Power : reader power from 0-18 level
Dminxfre : select Min. UHF frequency
Dminxfre : select Max UHF frequency
Baud : select com port baud rate
Max InventoryScanTime : select Scan time (e.g. 10*100ms = 1 second / scan)
Single Freq. : set single Frequency
FreqBand :
 User Band – can be defined by user (902.6Mhz to 927.4Mhz)
 Chinese Band2 – 920Mhz – 925Mhz
 US Band – 902-928Mhz
 Korean band – 917Mhz – 923Mhz
Set Parameter : save parameter value
Default Parameter : set to factory default setting

Set Reader output Parameter

Select Wiegand output parameter

Set Work Mode

Select UHF Tag type - EPC-G2 or ISO18000-6B

Select Output Interface - wiegand or RS232 output

Storage area or inquiry conducted Tags

Select data memory (Password , EPC ,TID , User or Inventory)

Activate or Disable buzzer

Work Mode :

Answer Mode :

Need send command to reader for operation , select this mode when do the Tag read / write testing

Active Mode : read Tag automatically and output data as the parameter setting

Trigger Mode (Low) : reader is triggered by Trigger pin (Low)

Trigger Mode (high) : reader is triggered by Trigger pin (Low)

SET : save work mode parameter

Get Work Mode Parameter : Get current work mode parameter

EPC – G2 Testing

After Reader Parameter and work mode setting , click on “EPCC1-G2 Test”

Remarks :

Work Mode need set to “Answer Mode” for operation.

Click on “Query Tag” to start Tag reading

Click on “Query Tag” once again to stop Tag reading

Similar operation for other button (Press once start and Press again to stop)

Other read/write operation , pls refer to EPC-G2 datasheet

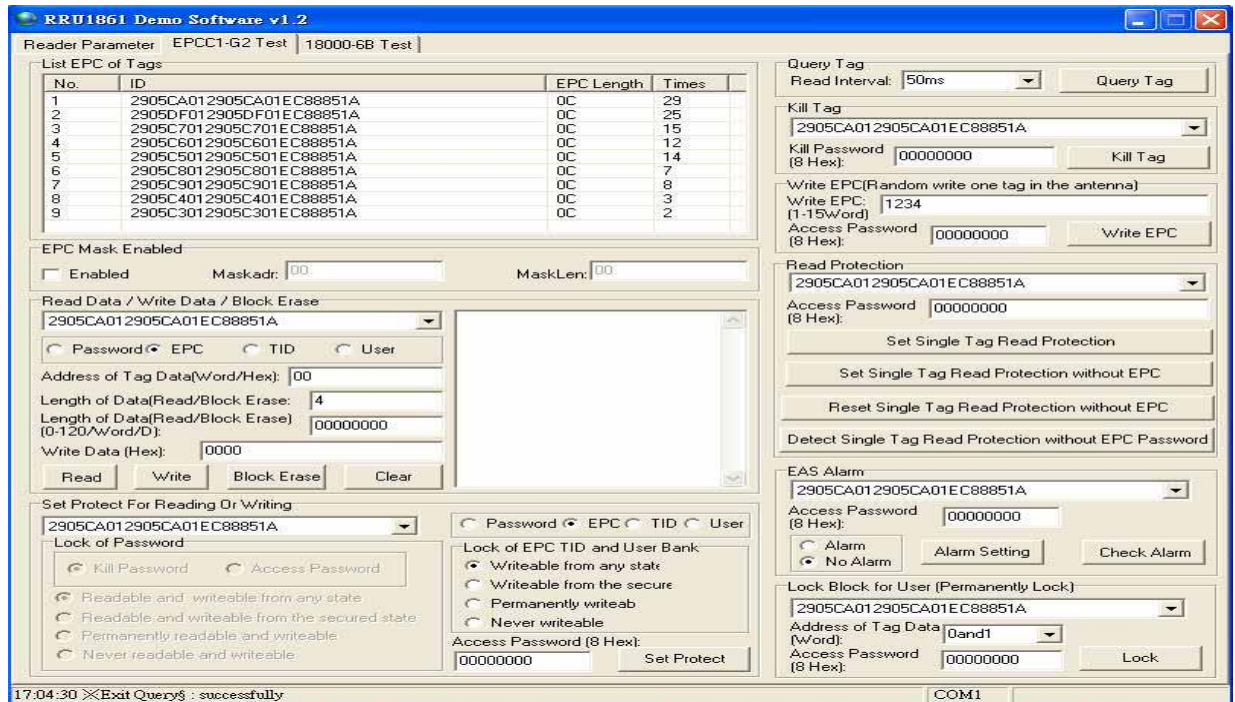

18000-6B Testing

After Reader Parameter and work mode setting , click on “18000-6B Test”

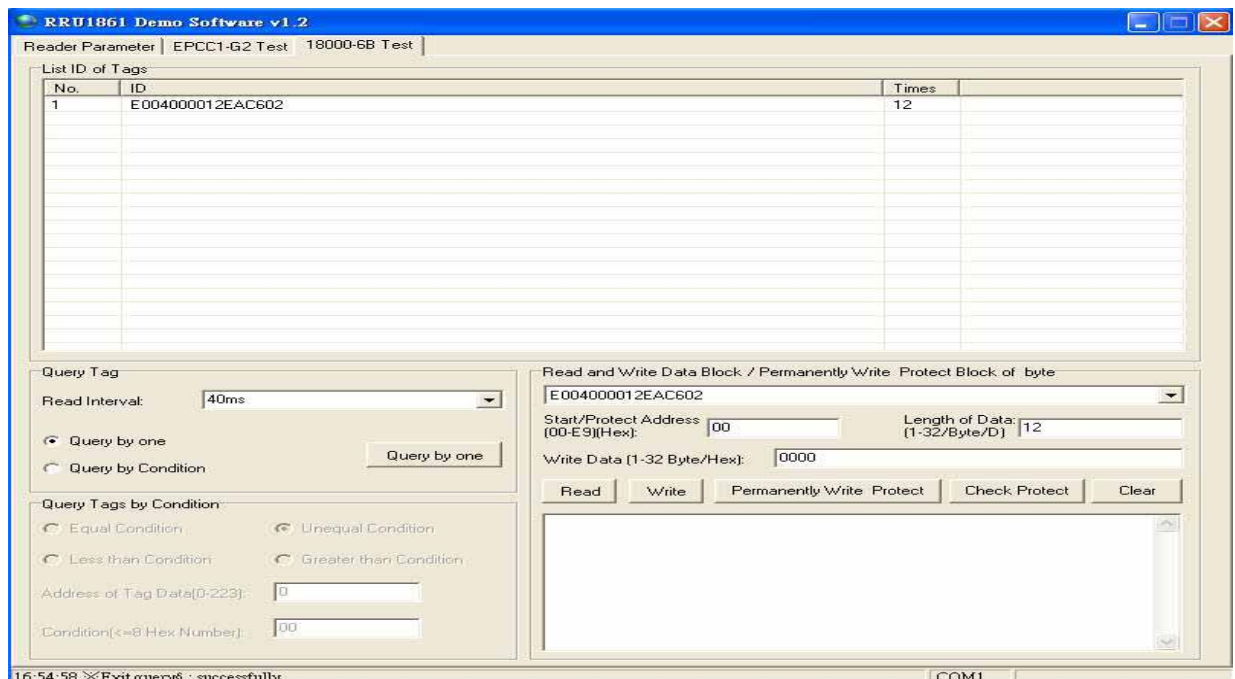

Other read/write operation , pls refer to 18000-6B datasheet in detail

Reader installation

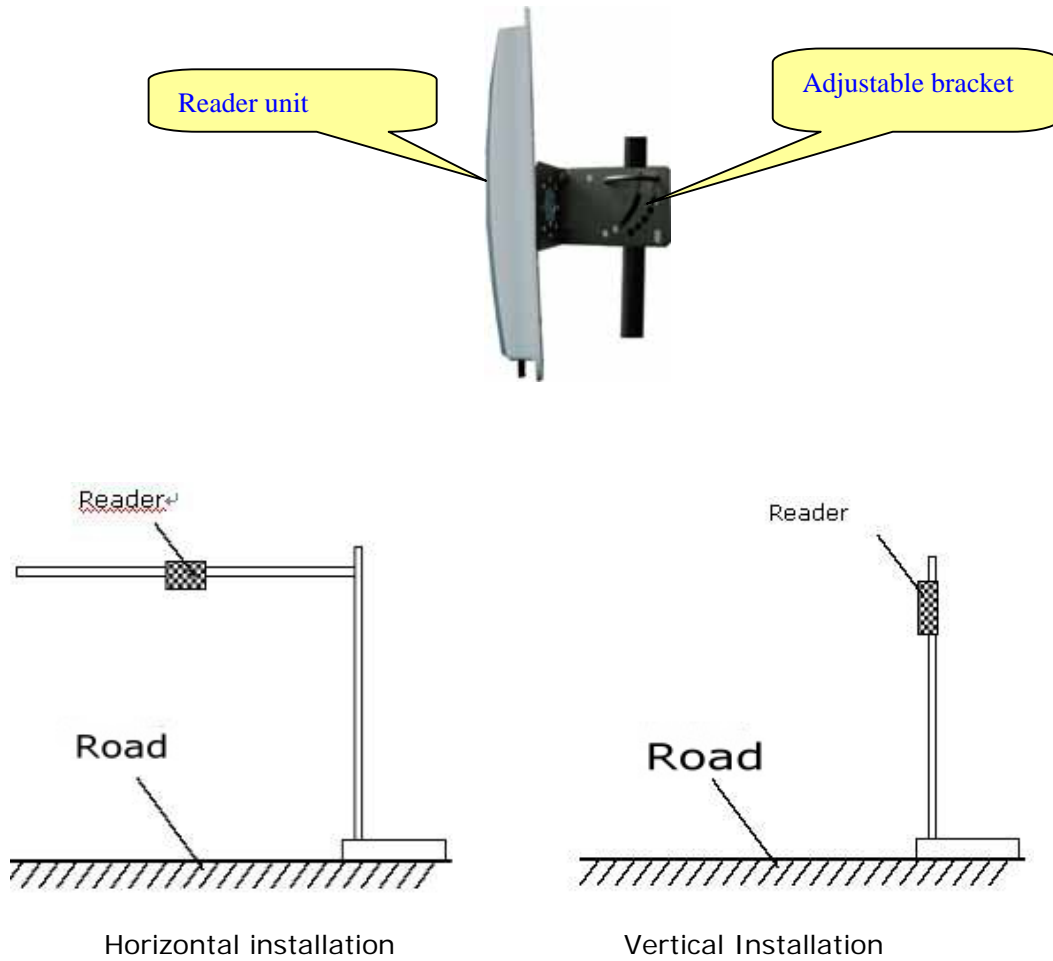

Adjust the reader to get the best detection performance

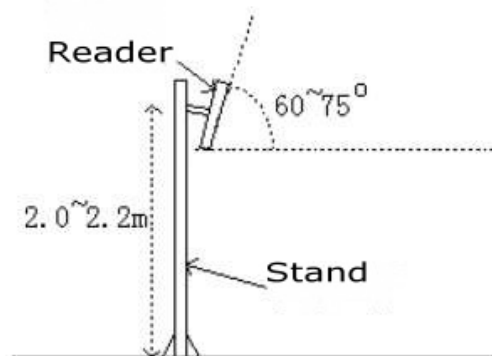

When measuring or testing the reader's read range, make sure that the tag is properly oriented to the reader antenna, and for optimum performance, be sure the operator's finger is not within three inches of the tag's antenna surface.

Environment Interference will affect the reading distance.